

# SEATS NZ INTEGRATED SEATBELT AIR SUSPENSION SEAT

## DRIVERS SEAT

A safe and comfortable air suspension seat for your vehicle. Integrated 3-point seat belt, removable headrest, self-levelling air suspension and anatomically shaped cushion and backrest foams are just some of the standard features in the SNZASSF-3PT.



### Features Include:

- Three Point Integrated Seat Belt
- Supports a weight range from 50kg - 130kg.
- Mechanical height adjustment of 65mm.
- Horizontal adjustment of 180mm.
- High backrest.
- Backrest adjustment.
- Lock out lever (locks suspension when off highway)
- Available in left & right hand controls.

### Accessories:

- Mounting boxes.
- Armrests
- Swivels



# SEATS NZ

## INTEGRATED SEATBELT

## AIR SUSPENSION SEAT

### TECHNICAL DRAWING

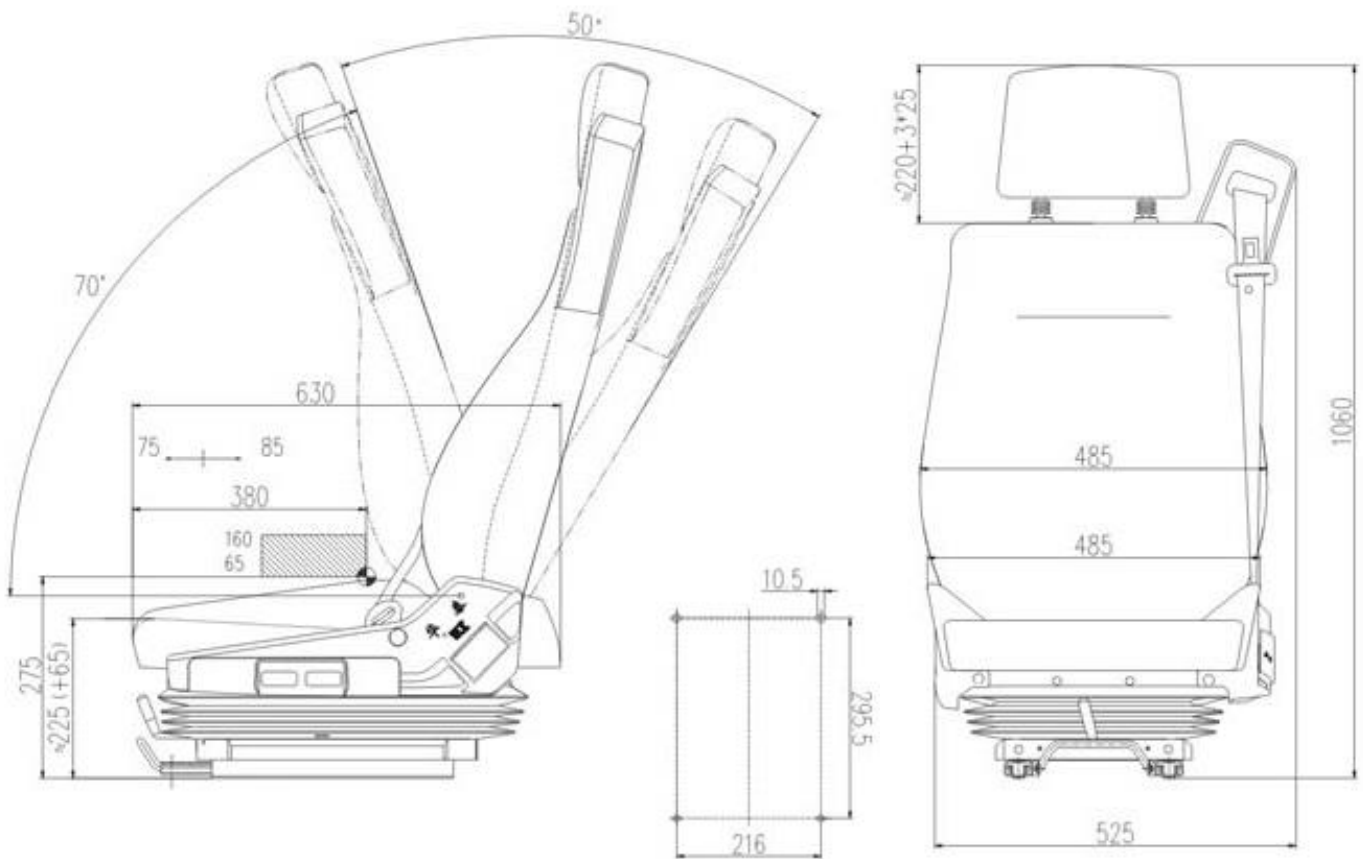

Please Note: This technical drawing may not accurately depict the exact dimensions as some seat models are subject to change without notification.